



ENGINE

Make: Volvo
Type: TAD883VE - Stage 5
Max. output: 235 kW (320hp) @ 2.200 rpm
Max. torque : 1300 Nm @ 1.400 rpm
Displacement : 7,7 lit.
Cylinders : 6 in line
Bore & stroke : 110 x 135 mm
Aspiration : Turbo and intercooler
Cooling : Watercooled

COOLING SYSTEM

Vertically built-in cooler

TRANSMISSION

Powershift transmission ZF 6WG211 with hydraulic torque converter
6 speeds forward en 3 reverse
Ratio's : 5,68 - 3,70 - 2,30 - 1,50 - 0,96 - 0,63
Rev. : 5,04 - 2,04 - 0,85
Safety installed to prevent change of direction while moving

TRANSFER BOX

Transfer box with continuous 4x4 drive and differential lock controlled from driver's cab

FRONT AXLE

Make : Kessler
Type: LT61PL375
Capacity : 20.000 kg (20km/h)
Wheel bolt protection on front wheels

REAR AXLE

Make : Kessler
Type: D81PL477
Capacity : 38.000 kg (20km/h)
Limited slip differential

SUSPENSION

Front : Parabolic leafsprings with 2 double acting shock absorbers
Rear : Directly mounted to the chassis

TYRES

Front : 11R22,5 Continental (2x)
Rear : 11R22,5 Continental (4x)

BRAKES

Pneumatic braking system, independently controlled front and rear with airdryer
Parking brake with spring brake cylinders working on the rear wheels
Air-pressure connections for coupling of semi-trailer behind the cabin
Air capacity: 120L

CABIN

Left hand drive
Tiltable one man cab with a 180° turnable and air suspended seat - ISRI 6860/880
Suspended cabin with anti-vibration mounts in combination with shock absorbers
Build in high quality steel plates and polyester, ROPS and FOPS tested
Opening of the sliding door is located at the back of the cab, safely accessible
Large, safety and tinted windows with front window layered
Vertical electric sliding driver's side window
2 large exterior rear view mirrors
Sun visors on the window for safety
Windscreen wiper and washer on front and rear window
Inside of the cabin ergonomically finished in plastic and metal

SWITCHES AND CONTROLS

Horn, Windscreen wipers, (Working-) Lights, Indicators,
flashing light, Parking brake, Transmission, 5th wheel, Start/Stop, Turnable chair

DASHBOARD

Fuel level, Oil pressure, Cooling water temperature, Air pressure,
Working hours, Speed/RPM, Transmission oil temperature, Voltmeter

CONTROL LIGHTS

High beam, Indicators, Parking brake, Low fuel level, 5th wheel

CABIN INNER DIMENSIONS

Width: 1.460 mm

Length: 1.640 mm

Height: 1.640 mm

FIFTH WHEEL

2" Fifth wheel

2 double-acting hydraulic cylinders

Unlocked pneumatically, operated from inside the cabin

Capacity: 36.000 kg

HYDRAULIC SYSTEM

Hydraulic valve, electrically operated, to lift/lower the fifth wheel

Gear type hydraulic pump

55L hydraulic tank

Return line with replaceable filter elements

ELECTRICITY

24 Volt negative ground

2 Batteries, 180 Ah.

24V starter, Alternator

Electrically activated, pneumatically operated horn

Electrically activated reversing signal (Reverse buzzer)

Battery isolation switch, Electrical connections for trailer

Engine safety: oil pressure, coolant temp., coolant level

LIGHTING

Halogen Headlights, LED Rear lights, Indicators, Beacon light

Dashboard and cabin interior light

Halogen work light behind the cabin

FRAME

Welded S355JO steel construction

Steps and walkways with non-slip surfaces

Tough front- and rear bumper

Steelplate protection for air-, fuel- and hydraulic tank

AIR INLET

Heavy duty multistage air cleaner with cyclone principle

EXHAUST

Exhaust muffler with vertical outlet and heat protection

With aftertreatment system (AdBlue)

FUEL SYSTEM

1 fuel tank of 200L
Waterseparator, Fuel cap

PAINTING

High build two pack primer/surfacer with high protection against corrosion
High build two pack acrylic lacquer with outstanding weather resistance
Cabin colour RAL by choice
Chassis colour RAL 7016

WEIGHTS

Empty weight: ca. 12.000 kg
Max G.C.W.: 150.000 kg

PERFORMANCES

Max. speed empty: ca. 40km/h (Limitation possible)
Max. tractive effort: ca. 290 kN

Possible options:

- Automatic airconditioning
- Air suspension with release valve
- LED lighting (Front, rear, behind the cabin)
- Plastic or steel rear fenders
- Chassis protection
- Radio
-

(Other options can be asked on demand)

TECHNICAL DRAWING

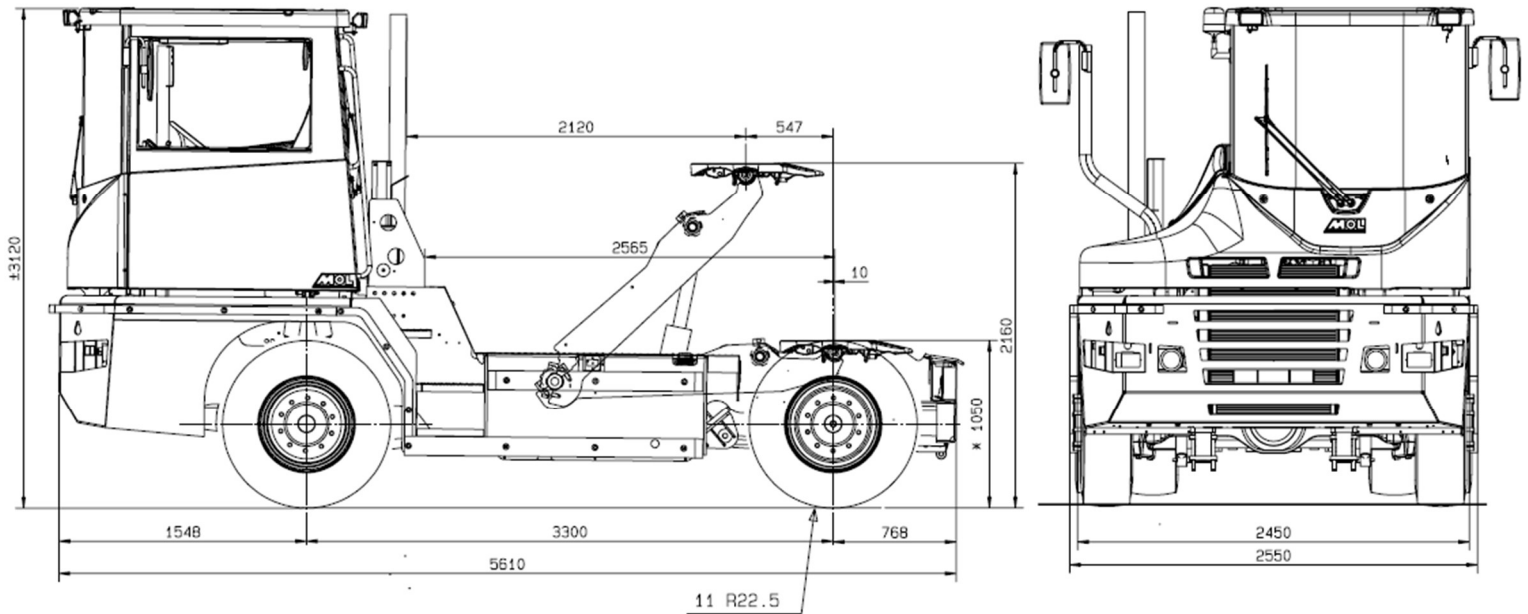

MOL CY NV
DIKSMUIDESTEENWEG 68
8840 STADEN - BELGIUM
www.molcy.com
Sales: ttsales@molcy.com